

JUMPING JACK[®]



JUMP • UP TENT TRAILERS

**TENT SETUP & TAKE DOWN
CARE & MAINTENANCE
INSTRUCTIONS**

**Failure to read and understand
"TENT SET UP & TAKE DOWN INSTRUCTIONS"
may result in damage to the tent
and or trailer and its components.**

SETUP

1- Tow Trailer to level surface.

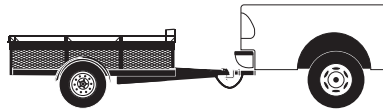

2- Swing Front Tongue Jack to vertical position, with Tilt Pin latched. Then remove trailer from tow vehicle.

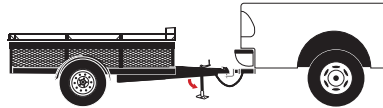

3- Lower Rear Stabilizer Jack by pushing forward and swinging down. Depress lever allowing end of jack to drop to ground.

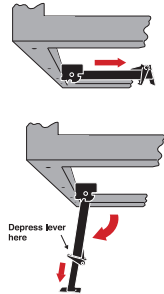

4- Crank out Front Tongue Jack to apply stabilizing pressure against Rear Stabilizer Jack.



5- Remove pins from tailgate (one on each side) and lower tailgate to horizontal position. Replace pins in side slots for storage.

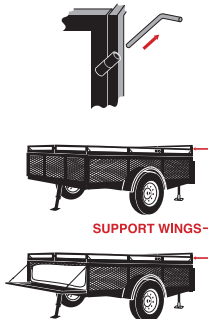

*NOTE: If support wings are not in closed position, tailgate may not be able to lower to horizontal position.

6- Open Folding Step and place at back end of trailer near tailgate.



*NOTE: Always use extreme caution when using step. Check that it is in open and secure position.

7- If utilizing front gate as a cook table, remove from front of trailer by removing pin and laying table flat and upside down on ground. Install 4 legs. Replace pin in slot on front of trailer.

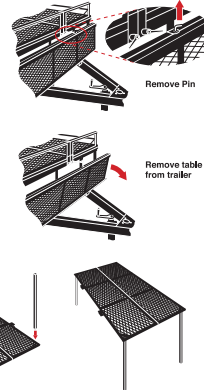

*NOTE: Never place fingers in wire mesh while handling end piece. Edges may be sharp and could cause serious injury.

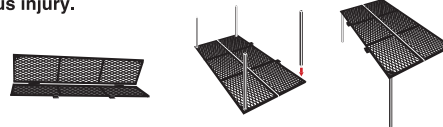

8- Remove security knobs at front of trailer. Store knobs in holes provided on front tongue.

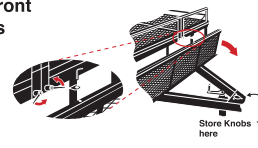

9- Open wings by grabbing top rung of either end, and hinging the wing to an open horizontal position.



*NOTE: Never hold on to the vertical struts of the wings, as your hands may be smashed.



10- Completely unzip the outer bag, and roll the top until it drops over front end of trailer bed, resting on the tongue.

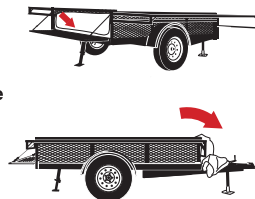

11- Unfold each side of the tent until it rests across the wing supports.



*NOTE: Always check the tension bar hinges to assure no tent material is caught in hinges.



Tug on upper tent sleeves to clear hinges.

12- Grasp tent by tension bar (near center), while standing on tailgate.



13- Lift towards chest, and step back off tailgate, using folding step, bringing the tent with you. This will allow the rear end of the tent to "jump-up".

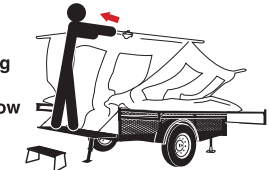

*NOTE: Always use caution when stepping on folding step.



14- Walk back up onto tailgate while lifting up top.

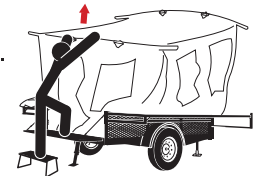

15- Holding up top with one hand, reach with other hand to support bar inside tent.



*NOTE: Always leave tent door open when storing tent, to allow access to support bar during set up and collapsing of tent.

SETUP

16- Pull support bar past vertical to cocked position.

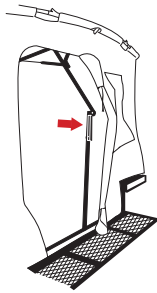

17- On either side of trailer, pull down on handles to provide tension on sides of tent. Hook the snap buckle to any opening in the wire mesh underneath the support wing, and tighten strap.

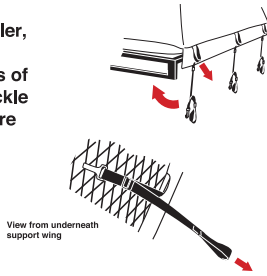

18- Repeat Step #16 for all 3 snap buckles on each side of trailer.

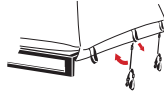

19- Inside the tent, place the two 13"x92" cushions on the wing beds with the rounded corners towards the side walls.

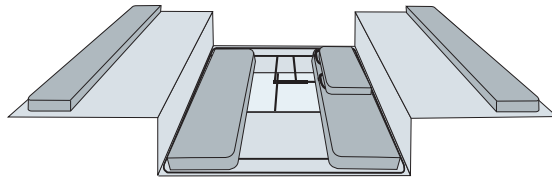

20- Place the two 21"x92" cushions on the wing beds, connecting them to the 13"x92" cushions with the Velcro flaps.

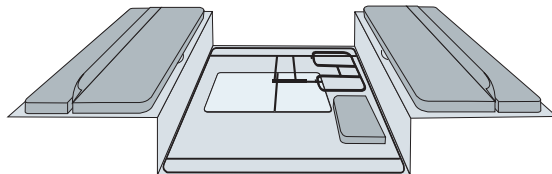

21- Place the Half Bed Extension (B) in place (A & C) by sliding the tongue through the slot and under the trailer wing. Ensure that the stop is seated against the trailer frame (D).

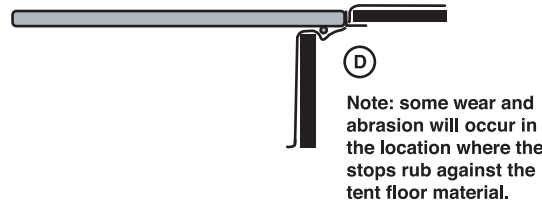
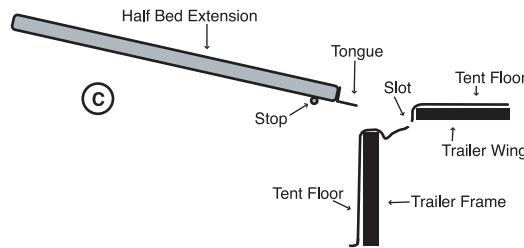
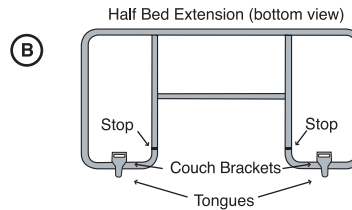
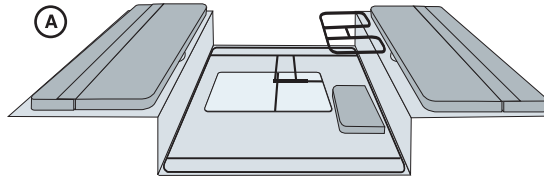

22- Place Half cushion on extension connecting it to the 21"x92" cushion with the Velcro flap.

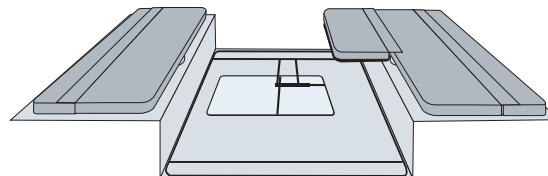

23- Lift table from floor and hinge top over to right side up position. Line up hole in table top with pin extending from tent upright support bar.

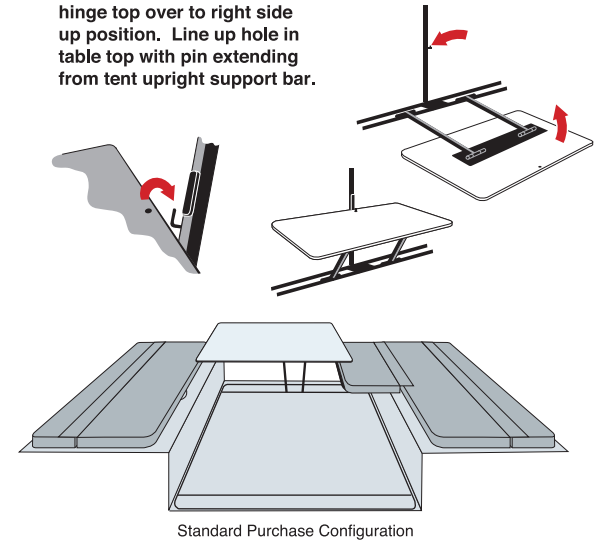

Note: If additional Half Bed Extensions are purchased, they are seated similarly. Table will need to be switched from position #1 to position #2 (sing a Phillips screwdriver) if Half Bed Extensions are used on both sides of trailer.

24- Additional Half Bed Extensions can be used as couch backs. Slide additional extension's tongues into already seated extension's couch brackets. Place half cushions as shown.

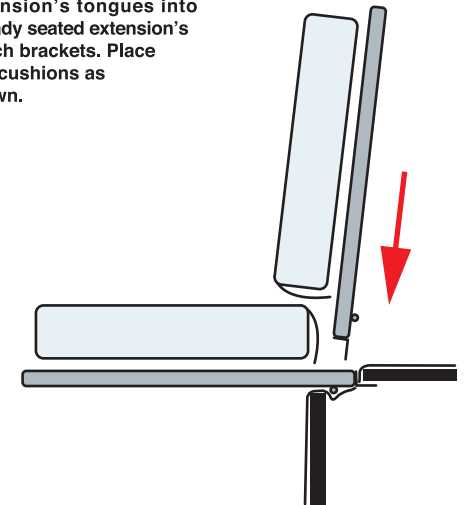

SETUP

TAKE DOWN

Possible configurations based on number of Half Bed Extensions

1 HALF BED EXTENSION - (Standard Purchase Configuration includes 1 Half Bed Extension)

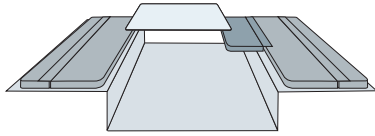

2 Single Beds (34"x92"), 1 Seat Extension (19"x46"),
1 Table (44"x32" position #1)

2 HALF BED EXTENSIONS - (Standard + 1 Half Bed Extension)

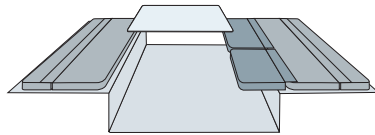

1 Single Bed (34"x92"), 1 Double Bed (53"x92"),
1 Table (44"x32" position #1)

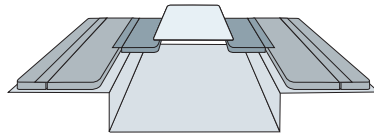

2 Single Beds (34"x92"), 2 Seat Extensions (19"x46"),
1 Table (32"x44" position #2)

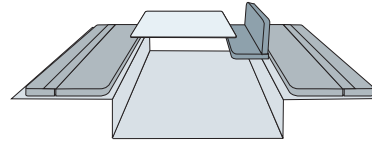

2 Single Beds (34"x92"), 1 Seat Extension (19"x46"),
1 Couch Back, 1 Table (44"x32" position #1)

3 HALF BED EXTENSIONS - (Standard + 2 Half Bed Extensions)

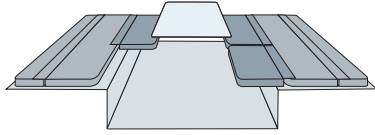

1 Single Bed (34"x92"), 1 Seat Extension (19"x46"),
1 Double Bed (53"x92"), 1 Table (32"x44" position #2)

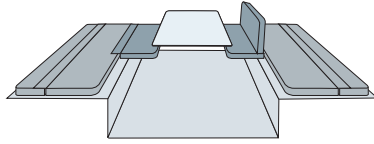

2 Single Beds (34"x92"), 2 Seat Extensions (19"x46"),
1 Couch Back, 1 Table (32"x44" position #2)

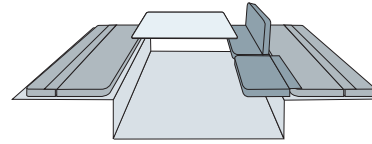

1 Single Bed (34"x92"), 1 Double Bed (53"x92"),
1 Couch Back, 1 Table (44"x32" position #1)

4 HALF BED EXTENSIONS - (Standard + 3 Half Bed Extensions)

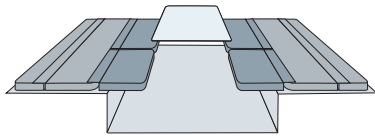

2 Double Beds (53"x92"),
1 Table (32"x44" position #2)

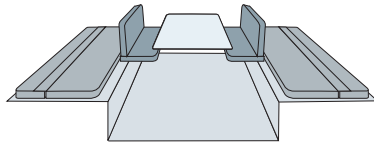

2 Single Beds (34"x92"), 2 Seat Extensions (19"x46"),
2 Couch Backs, 1 Table (32"x44" position #2)

Note: Half Bed Extensions are sold separately. Other configurations possible.

1- Lift table off pin on back support bar, by depressing flexible plastic lock while pulling up on the back end of table.

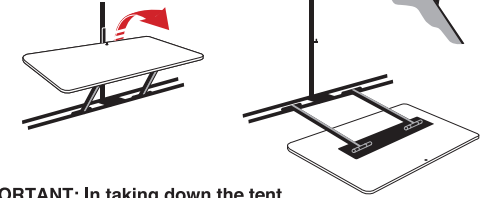

IMPORTANT: In taking down the tent, the table must be set down before the beds, and must be set down upside down.

2- Place the two 13"x92" cushions vertical against sides of trailer frame. This is important to support the tent bag when closed.

3- Place the two 21"x92" cushion horizontal on floor, against each 13"x92" cushion.

4- Place Half Bed Extension on top of 21"x92" cushion with tongues toward center.

5- Place Half Cushion on top of Half Bed Extension.

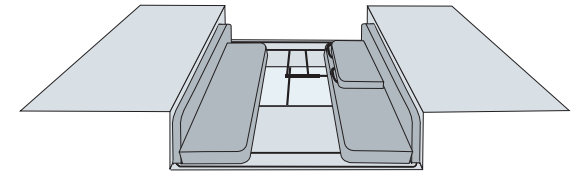

Note: If additional Half Bed Extensions are purchased, they are placed similarly on top of 21"x92" cushions

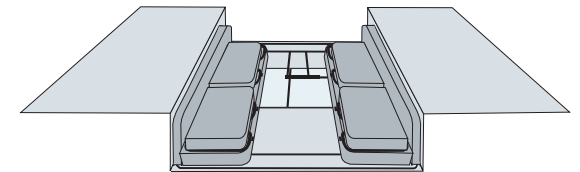

TAKE DOWN

6- Stand in tent and pull front support bar until bottom and top halves are straight to each other, and slide support lock up. Relax support bars to hold support lock in place.

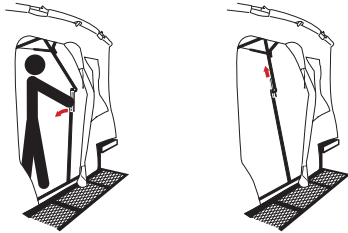
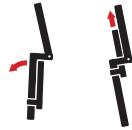

7- Collapse rear support bars. Gently lower back end to floor.

*NOTE: Use caution to not place hands in areas near hinges, where they may be pinched during collapsing.

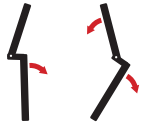

8- Collapse front support bar (lock support will automatically lower out of the way).

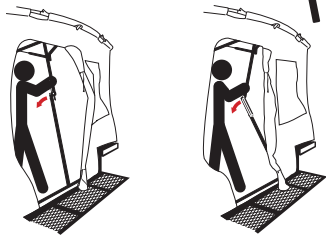
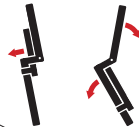

9- Step out of tent and lower front of tent to trailer level.



10- Fold any extra side tent material under tent roof.



11- Unhook snap buckles from wire mesh of both support wings. Lay tension on top of material.

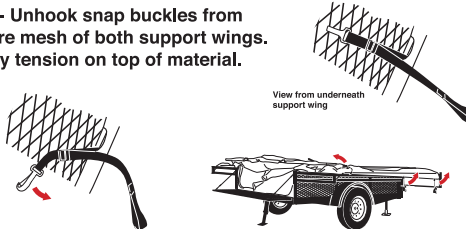

12- Push tent material (especially window screen and rain fly) under and away from tension bar hinges.

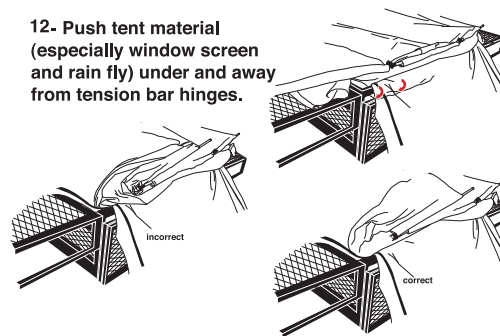

Always expose tension bar hinges, tuck rain fly (tongue side) under tension bar so as to not cover hinges.

13- Fold door side top over, then fold remaining tent material over.



14- Fold non door side top over. Fold remaining tent material over, making sure folded tension bars are not being held "up" for some potentially damaging cause.



15- Zip outer bag closed and tuck and velcro bag rainflies down between bag and trailer bed walls.

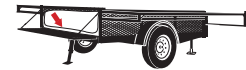

16- Close support wings by holding top rung and hinging over to closed position.

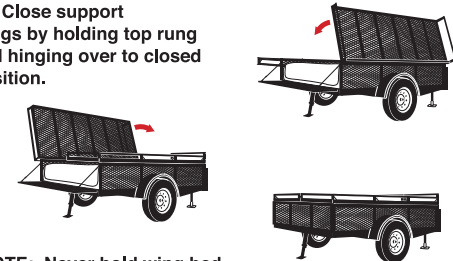

*NOTE: Never hold wing bed or vertical struts.

Never grasp wire mesh.

Secure support wings down by screwing security knobs into original location.

CARE AND MAINTENANCE

- Lubricate hinges and joints as needed to keep them operating smoothly. Do not allow lubricant to overspray onto fabric at all. While spraying a lubricant, shield all but the hinge with a rag and wipe off part thoroughly.
- Arrest rust spots by cleaning and spraying with high gloss black Rustoleum or equal ASAP.
- Never store a tent in a moist condition. Always thoroughly dry tent before prolonged storage.
- Do not add chemical water repellency products to tent.
- Tighten lugs periodically.
- Grease hubs periodically.
- Check tire pressure periodically.
- In the event that rust appears over time or through rock chips or damage, clean area and arrest the rust by spraying a high grade Rustoleum type metal paint in high gloss black.
- Over time, working hinges may begin to "tighten". Simply spray with lubricant. Caution: Be extremely careful to avoid getting oil on fabric as it will cause loss of water repellency.
- From time to time, as you use your Jumping Jack trailer, you will necessarily need to "set down your tent" in a wet condition. Traveling home from camp with a wet tent stowed away is no problem. However, do not allow the tent to remain stowed in a wet condition for more than one day. Simply set up and thoroughly dry out your tent when you get home. In the event that you set down a wet tent and travel from cooler mountain conditions into hot city conditions, your wet tent will steam inside it's completely enclosed protective bag. Under these circumstances, leave the entire "tailgate end" of the bag unzipped to allow the tent to ventilate as you travel home. This will still protect the tent from wet conditions as you travel.
- In the event that it is necessary to collapse a wet tent, leave the last end portion of the protective outer bag unzipped to allow the folded up wet tent to breathe while transporting it home. Failure to let the bag "breathe" may cause "steaming" inside the bag when coming from colder conditions to hot city conditions.
- Weather conditions may affect the operation of your Jumping Jack. If your tent is extremely wet, for example, the fabric will be heavier, causing the "jump-up" function of the tent frame to work more slowly. Cold weather may also make the tent springs somewhat sluggish. This is normal; your Jumping Jack tent should still operate.
- If you cook in the tent, make sure no grease or oil splashes on the tent walls. These substances could ruin the tent's water repellency.
- DO NOT ALLOW THE ZIPPER OF THE OUTER VINYL BAG TO SIT IN WATER. PROP BAG FOR WATER TO RUN OFF, OR COVER WITH TARP.

MANUFACTURER RECOMMENDATION FOR MAXIMIZING PERFORMANCE OF TENT MATERIALS

Prior to first using tent, practice all Set Up and Take Down procedures.

With the tent set up, and door and windows zipped close, completely spray tent with water.

Let tent thoroughly dry before take down and storage.

This procedure will help tighten seams.

KITCHEN CONVERSION

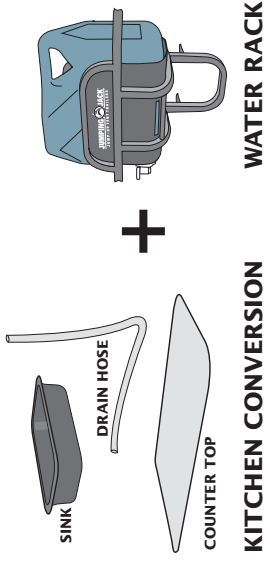

+

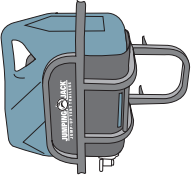

+

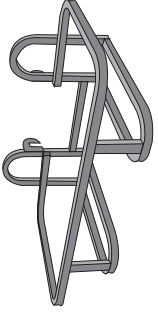

=

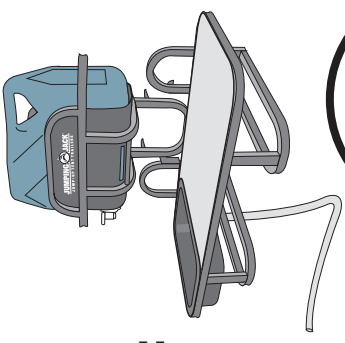

1

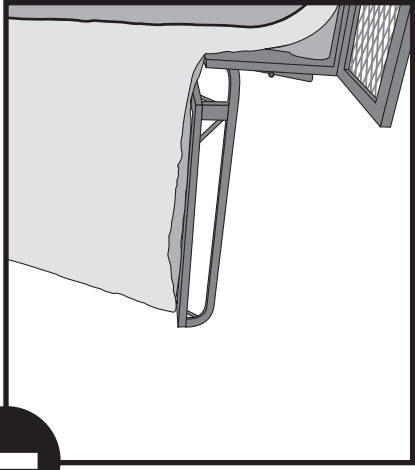

1-Use Kitchen Conversion in conjunction with Water Rack and Cooler Rack (each sold separately). Mount to open trailer wing with tent set up.

3

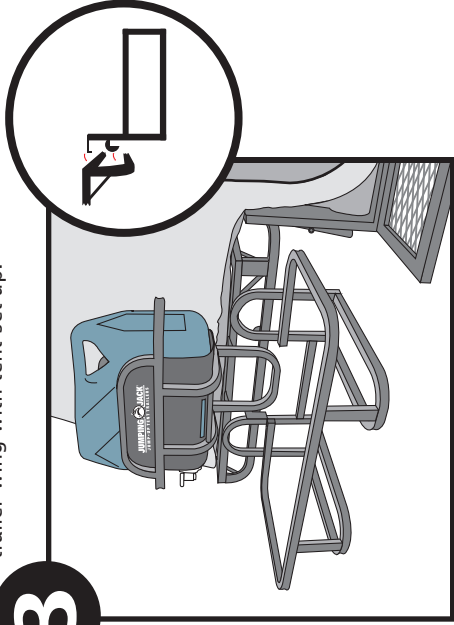

3- Mount Cooler Rack with hooks on both top of trailer wing and rail underneath.

5

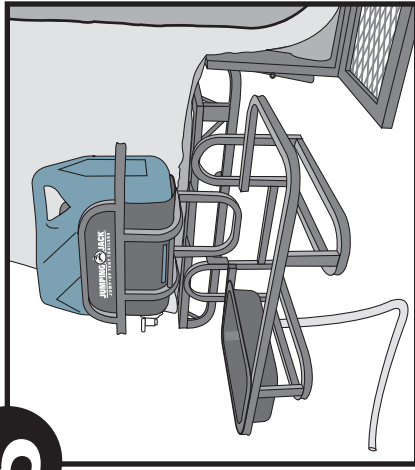

5- Connect Drain Hose to Drain Hole.

2

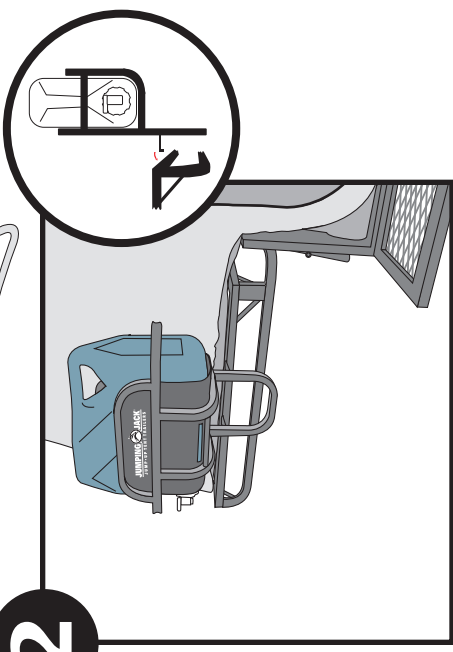

2- Mount Water Rack with hooks seated on top of open trailer wing.

4

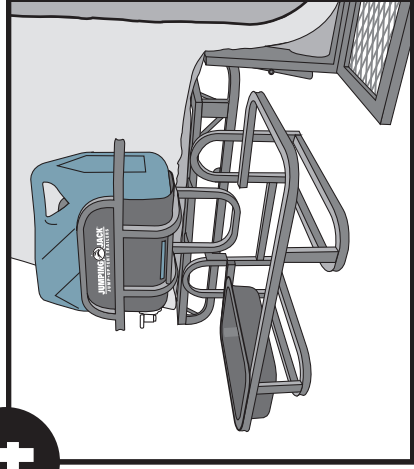

4-Place Sink in Cooler Rack underneath water spigot.

6

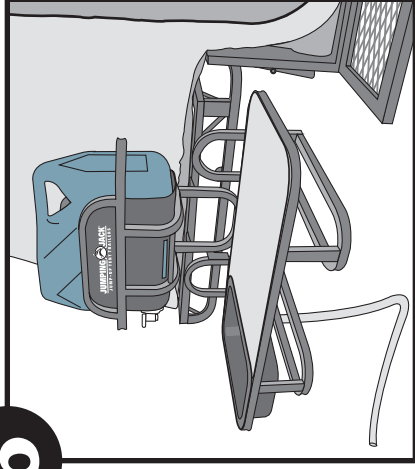

6- Place Counter Top on top of Cooler Rack and under Sink lip.

AWNING

1- Open and Unfold Tent.

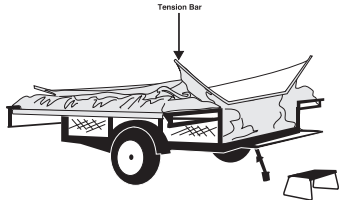

2- Lay out awning upside down.

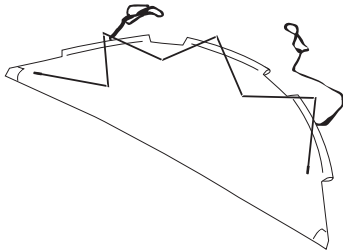

3- Run shock cord through 3 sleeves of awning and into pockets on each end of awning.

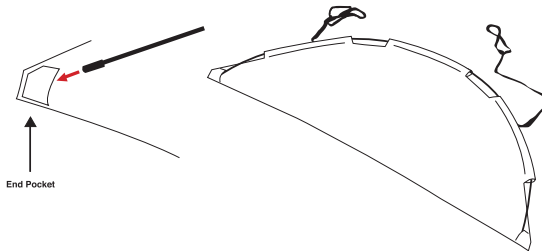

4- Put tension bar ends into end pockets of awning.

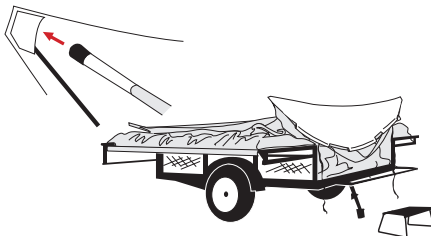

5- Flip awning over on top of tent. Allow straps to hang over front of tent.

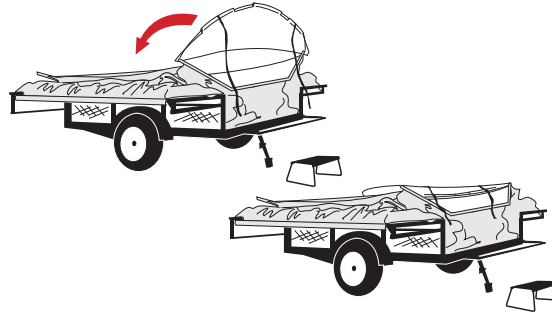

6- Set tent up with one foot on tailgate and the other on the step. Grasp tent by tension bars near the center and trace a square slowly:

A- Bring up level to head.



B- Towards nose backward.



C- Down to lap.



D- Forward and up.

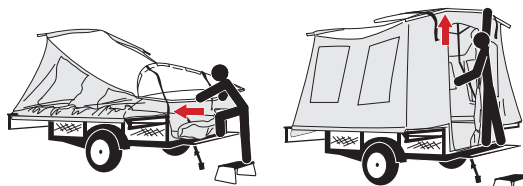

7- While standing on tailgate and holding tent up, grab upright and pull towards body to lock.



8- Use straps to flip awning forward into position over front of tent.

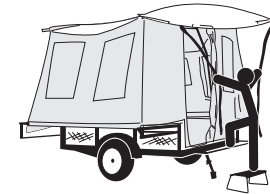

9- Attach straps snugly (not tightly) to outside corners of fold-out wings.



PROPANE RACK

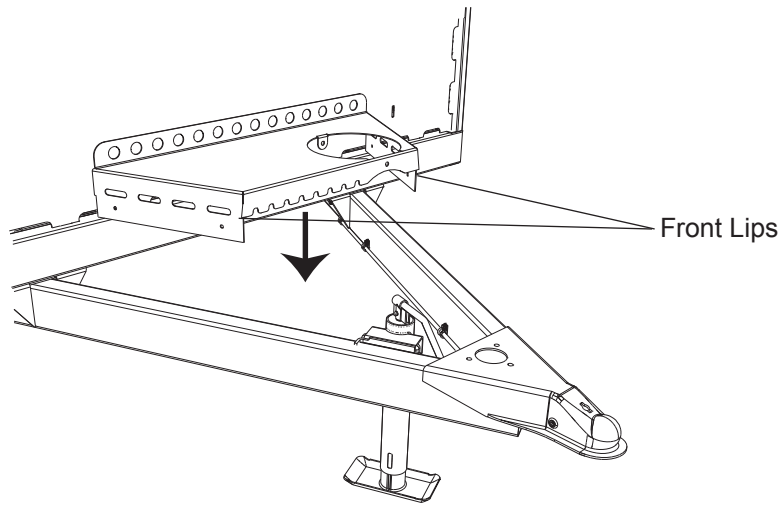

1 Set Propane Rack down into the "V" opening of the tongue so the front lips of the Propane Rack rest on the top of the tongue.

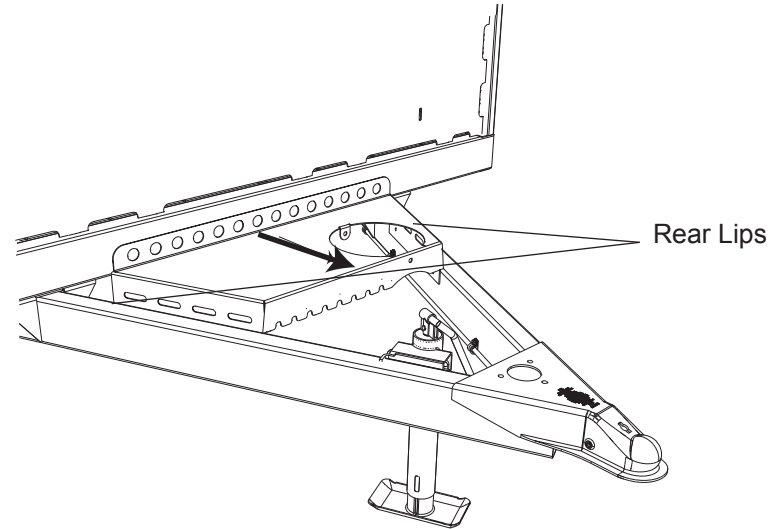

2 Slide Propane Rack forward as far as possible. Hold Propane Rack in place so rear lips are level with the top of the tongue.

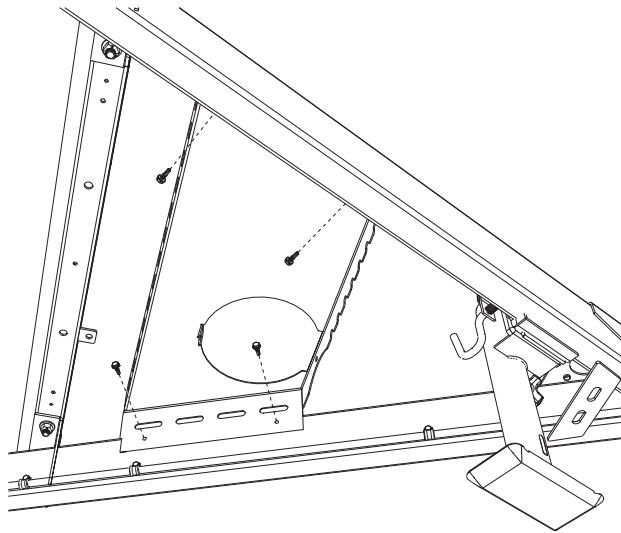

3 Starting at the rear holes, insert the four self-tapping screws to secure the Propane Rack to the tongue, as shown.

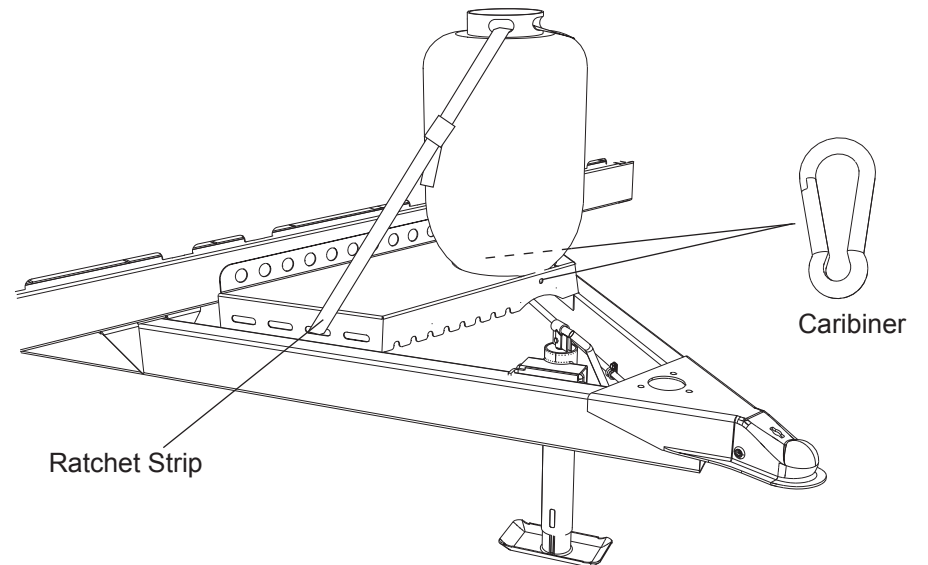

4 Lock down the Propane Tank to the Propane Rack using the two Carabiners and the Ratchet Strip (provided).

COOLER RACK

1.

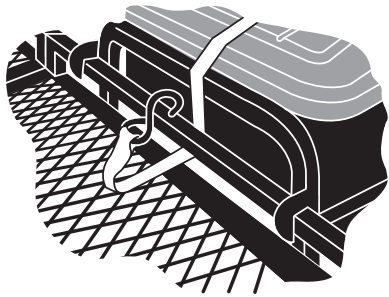

2.

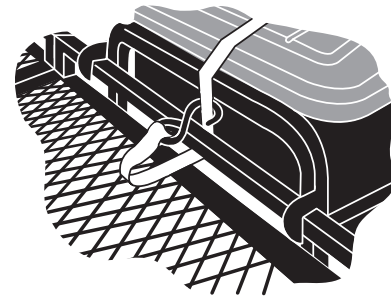

3.

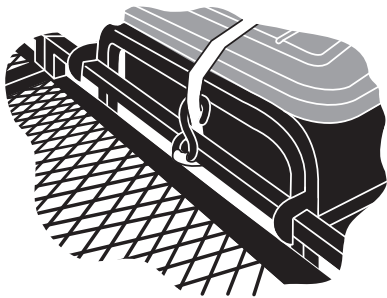

4.

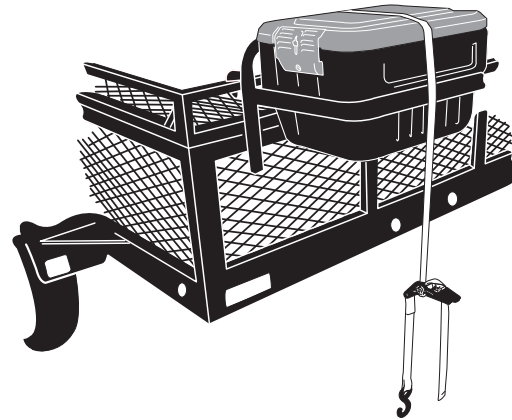

5.



Never travel without securing racks to trailer.

All racks secure in same manner.

COOLER RACKS mount on front or rear of trailer.

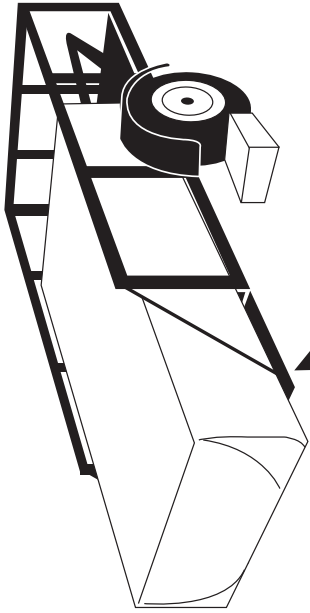

1- Block wheels.

2- Lift and slide tent bag approximately 2 feet out of trailer or until hole for tire bracket is exposed.

***(Be careful not to drag tent bag across tailgate cable lines! Lift bag while sliding)**

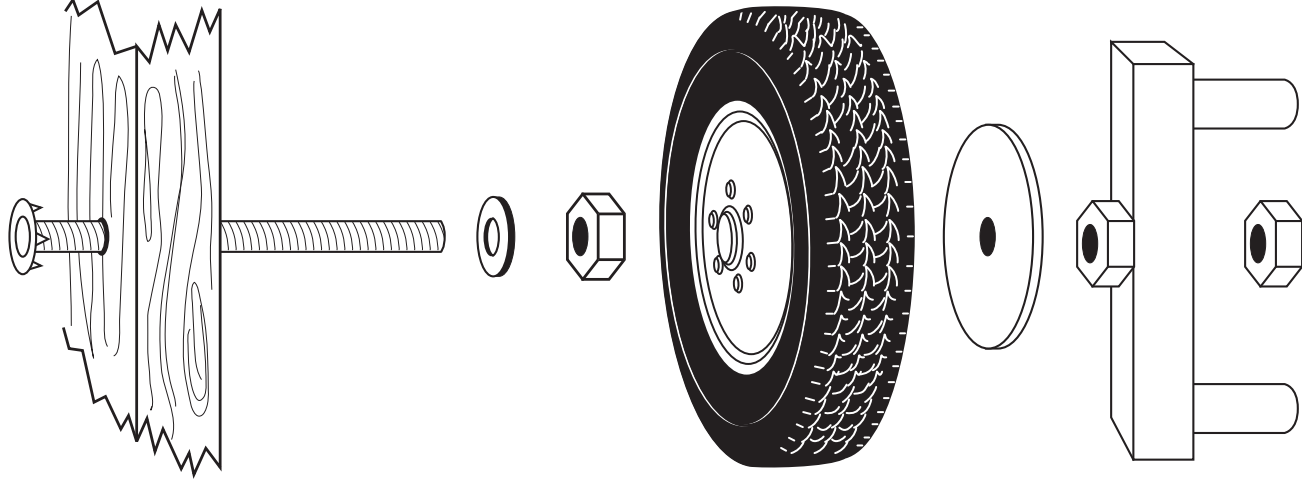

3- Insert t-nut with threaded rod into hole and tap down with hammer.

4- Place washer and nut under wood deck and tighten. Tap t-nut again with hammer and retighten nut until t-nut is nearly flush with upper surface.

5- Next: Install tire, plate and crank and tighten snug.

6- Finally: Place remaining nut onto threaded rod and tighten against crank to prevent unwanted loosening.

IMPORTANT

THE TENT ENCLOSURE IS INTENDED TO PROTECT THE TENT AND INTERIOR MATERIALS DURING NORMAL USE AND TRAVEL. IT IS NOT INTENDED TO THOROUGHLY PROTECT THE TENT DURING EXTENDED STORAGE, INCLUDING INCLEMENT WEATHER OR HARSH EXPOSURE TO SUNLIGHT.

IN ORDER TO ENSURE THE INTENDED LONGEVITY OF THE PRODUCT AND THE VALIDITY OF ANY WARRANTY, WE RECOMMEND THE FOLLOWING:

- 1- INSPECT TENT AND INTERIOR MATERIALS AFTER EACH USE AND AFTER EACH TRAVEL, TO ENSURE THAT ALL MATERIAL IS THOROUGHLY DRY BEFORE STORING.
- 2- ADEQUATELY COVER THE TRAILER TO PREVENT PROLONGED EXPOSURE TO MOISTURE AND SUNLIGHT BY USE OF A JUMPING JACK TRAILER COVER OR OTHER APPROPRIATE COVERING.
- 3- PERIODICALLY INSPECT MATERIALS TO VERIFY THE COVERING IS EFFECTIVE.

Save this instruction in the event that the manufacturer has to be contacted for replacement parts.

****U.S. and Canada customers ONLY****

IF ASSISTANCE IS NEEDED,

DO NOT CONTACT THE STORE!

CALL OUR CUSTOMER SERVICE DEPARTMENT at 1 (800) 225-3865

HOURS: 7:00 a.m. to 5:00 p.m. Monday through Friday (Mountain Standard Time)

****Call, or visit our Web site for Saturday hours****

****For customers outside the U.S. or Canada, please contact the store for assistance.****



UTILITY TRAILERS